

HYDRAULIC STACKER

Capacity : 500 & 1000 kg. Lift : 1500, 2500 & 3000 mm

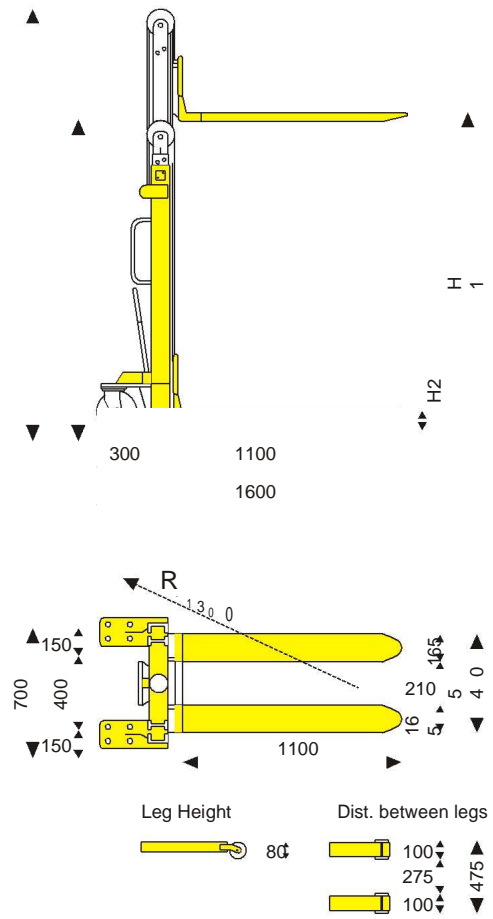

TECHNICAL SPECIFICATIONS



APPLICATIONS

- Used in press shops for loading & unloading of heavy die punches.
- Used in plastic and rubber industries for loading and unloading of moulds.
- Used in stores for stacking of materials, trays, boxes etc.
- Used in transport godowns, warehouses for material loading in trucks.
- Used in engineering industries for handling of heavy jobs, plates on various machines like CNC, VMC, Lathe, Milling, Shaping machine etc.
- Overall Size - L 1600 x W 700 mm
- Front Wheels - Dia 82 x 96 mm - 2 Nos.
- Steering Wheels - Dia 200 x 50 mm - 2 Nos.

MODEL	STO515T	STO525T	STO530T	ST1015T	ST1025T	ST1030T
Lifting capacity (kg)	500	500	500	1000	1000	1000
Max. fork height H1 (mm)	1500	2500	3000	1500	2500	3000
Min. fork height H2 (mm)	100	100	100	100	100	100
Load center (mm)	600	600	600	600	600	600
Lift per stroke (mm)	20	20	20	20	20	20
Min turning radius (mm)	1300	1300	1300	1300	1300	1300
Fork length (mm)	1100	1100	1100	1100	1100	1100
Width over forks (mm)	540	540	540	540	540	540
Min. overall height H3 (mm)	1600	2100	2400	1600	2100	2400
Max. overall height H4 (mm)	2300	3300	3900	2300	3300	3900

STACKER WITH INTERCHANGEABLE ACCESSORIES

Capacity : 500 & 1000 kg. Lift : 1500, 2500 & 3000 mm



- Provides a practical and most economical way of solving regular lifting problems.
- Highly versatile stacker design to suit various interchangeable accessories for maximum flexibility of use.
- Attachments are fitted on sliding frame with nut and bolts and requires small time to change.



FORKS



PLATE ON FORKS



ROLLER TABLE ON FORKS

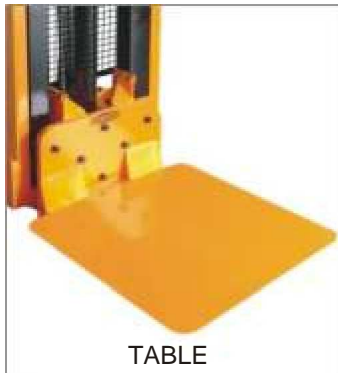

TABLE



SAFETY CAGE ON FORKS



BOOM



JIB CRANE



DRUM TONGS VERTICAL



DRUM TONGS HORIZONTAL

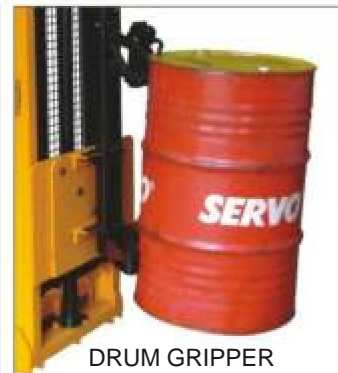

DRUM GRIPPER



DRUM TILTER

SEMI ELECTRIC STACKER - 24V BATTERY, DC SUPPLY

Capacity : 500 & 1000 kg. Lift : 1500, 2500 & 3000 mm



TECHNICAL SPECIFICATIONS

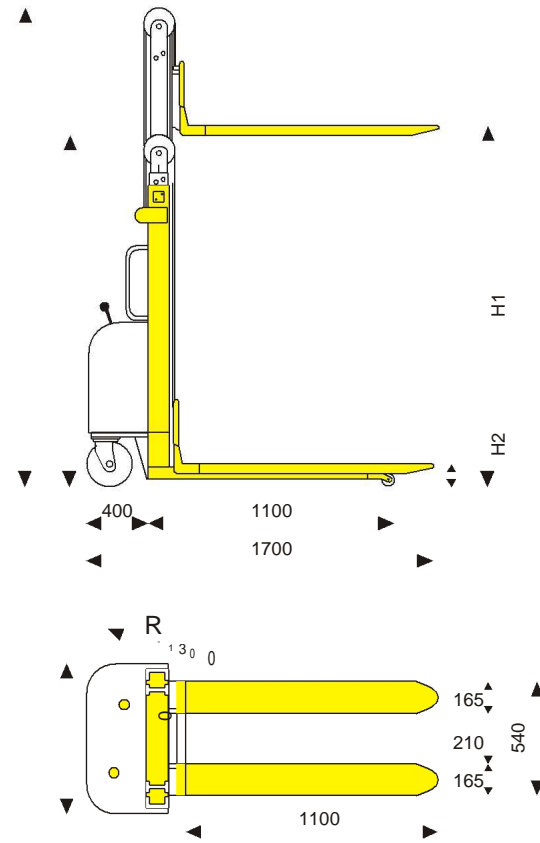

- Load Center - 600 mm
- Lifting Speed - 0.08 m/sec.
- Fork Length - 1100 mm
- Width over forks - 540 mm
- Overall size - L 1700 x W 700 mm
- Front wheels - Dia 82 x 96 mm - 2 Nos.
- Steering wheels - Dia 200 x 50 mm - 2 Nos.

- Up & Down movement with 24 V Battery & manual pulling & pushing.
- 3 HP, 24 V DC electric motor for lifting with Dowty make oil gear pump.
- BCH make adjustable height limit switch.
- Operated by 24 V heavy duty contactor.
- Lever operated directional control valve with inbuilt pressure relief valve for up & down movement.
- Oil tank with oil level indicator, oil breather, suction strainer etc.
- Battery - 24 V, 85 Amp - Hr, Tubular monoblock.
- A separate 24 V DC, 230 V AC battery charger is needed to charge a battery.

Semi Electric Stackers are available in counter balanced type (cap. 500kg) as well as in straddle leg stackers with adjustable forks (cap. 500 & 1000 kg.).

MODEL	STO515 SE DC	STO525 SE DC	STO530 SE DC	ST1015 SE DC	ST1025 SE DC	ST1030 SE DC
Lifting capacity (kg)	500	500	500	1000	1000	1000
Max. fork height H1 (mm)	1500	2500	3000	1500	2500	3000
Min. fork height H2 (mm)	100	100	100	100	100	100
Min. Overall Height H3 (mm)	1600	2100	2400	1600	2100	2400
Max. Overall Height H4 (mm)	2300	3300	3900	2300	3300	3900



SEMI ELECTRIC STACKER - 440 V, 3 PHASE AC SUPPLY

Capacity : 500 & 1000 kg. Lift : 1500, 2500 & 3000 mm



- Up movement with push button, down movement with precised controlled needle valve and manual pulling and pushing.
- 2 HP, 3 phase, 440 V AC electric motor for lifting.
- Dowty make oil gear pump.
- BCH make adjustable height limit switch.
- Operated by 440 V, L&T MNX contactor.
- Oil tank with oil level indicator, oil breather, suction strainer etc.

POWER PACK



FLAME PROOF MODEL IS ALSO AVAILABLE

SEMI ELECTRIC ORDER PICKER

Capacity : 300 kg. Including Operator, Lift : 2500, 3000, 4000 mm



- Reduces strain & fatigue, increases safety & productivity in continuous picking application such as stores etc.
- Up & down control push buttons are in cage for adjustment of cage to any desired heights.
- Extra side stabilizers are provided for additional safety.
- Cage size is 1000 x 1000 mm with 750 mm side railing & 1200 mm back net for safety.



AVAILABLE IN BATTERY OPERATED
24 V DC SUPPLY AS WELL AS IN 440
V, 3 PHASE AC POWER SUPPLY

FIXED MAST STACKER

Capacity : 500 & 1000 kg. Lift : 1500 mm



Overall size - L 1600 x W 700 mm x H 2200 mm
 Front wheels - Dia 82 x 96 mm - 2 nos.
 Steering wheels - Dia 200 x 50 mm - 2 nos.

MODEL	STO515 F	ST1015 F
Lifting capacity (kg)	500	1000
Max. fork height H1 (mm)	1500	1500
Min. fork height H2 (mm)	100	100
Load Centre (mm)	600	600
Lift per stroke (mm)	20	20
Min Turning Radius (mm)	1300	1300
Fork Length (mm)	1100	1100
Width over forks (mm)	540	540
Min. overall height H3 (mm)	2200	2200
Max. overall height H4 (mm)	2200	2200

STRADDLE STACKER WITH ADJUSTABLE FORKS

Capacity : 500 & 1000 kg. Lift : 1500, 2500 & 3000 mm



- Adjustable Forks
 Min. Distance over Forks - 350 mm
 Max. Distance over Forks - 800 mm

ALL OTHER SPECIFICATIONS
 SIMILAR TO REGULAR STACKER

TECHNICAL SPECIFICATIONS

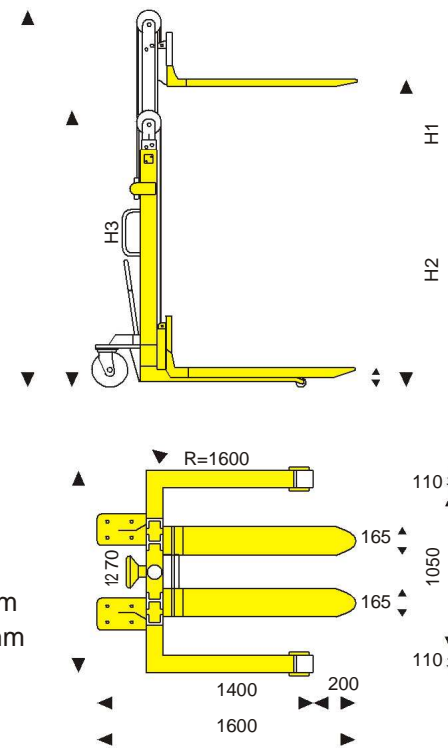

MODEL	STO515 SL	STO525 SL	STO530 SL	ST1015 SL	ST1025 SL	ST1030 SL
Lifting capacity (kg)	500	500	500	1000	1000	1000
Max. fork height H2 (mm)	1500	2500	3000	1500	2500	3000

COUNTER BALANCED STACKER

Capacity : 500 kg. Lift : 1500, 2500 & 3000 mm



TECHNICAL SPECIFICATIONS

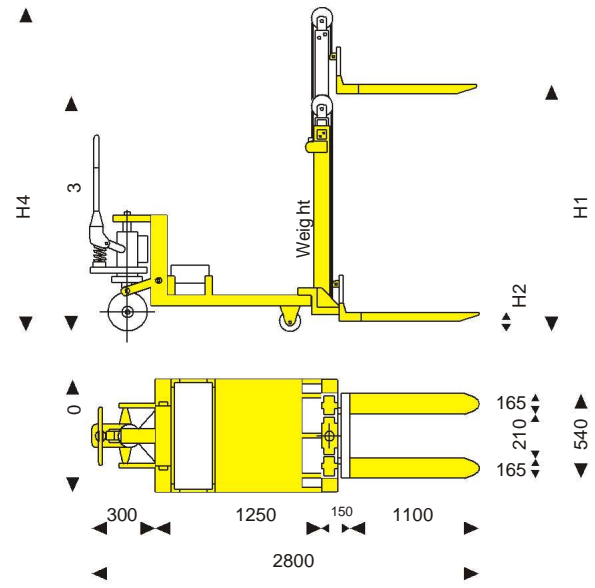
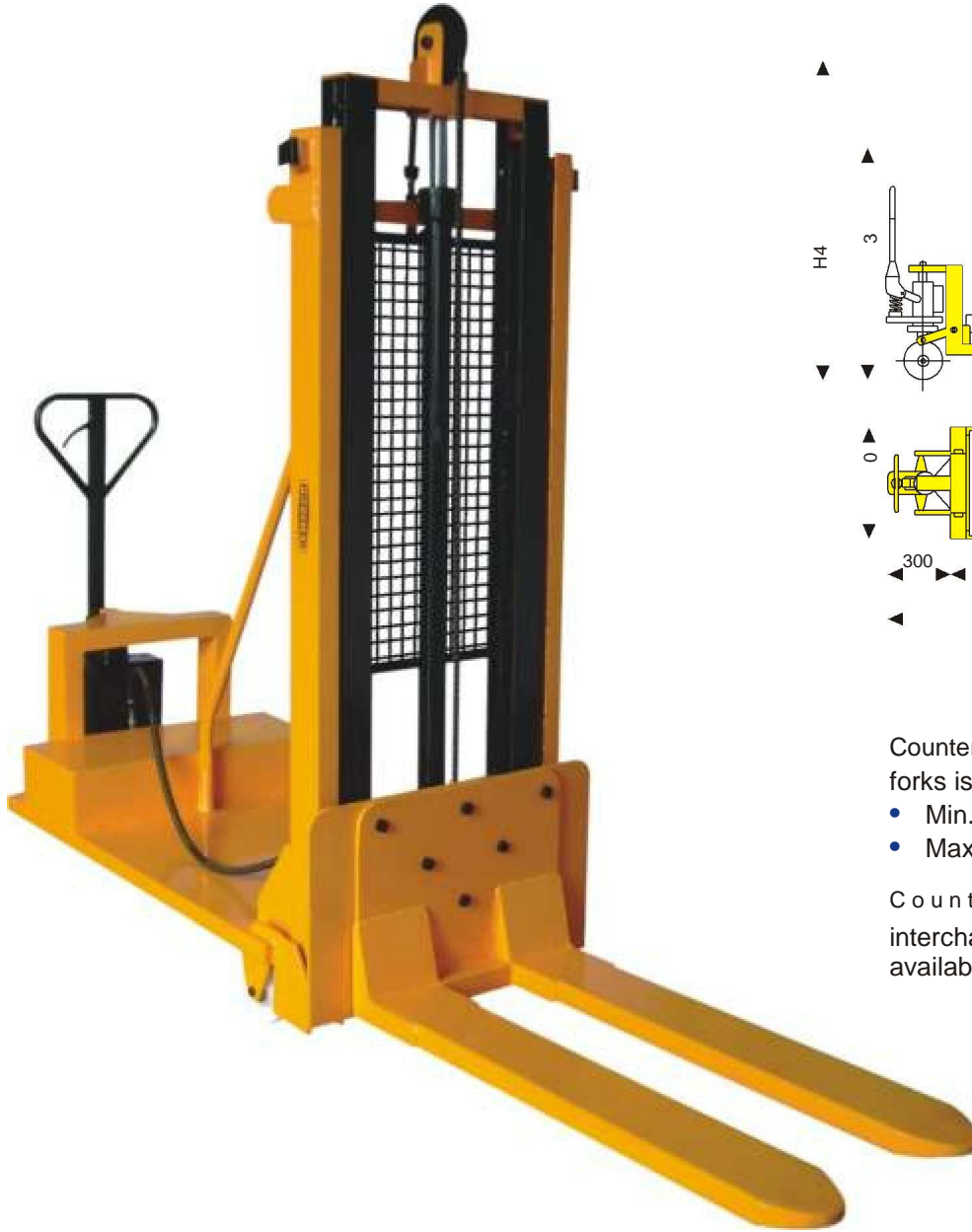

Counter balanced stacker with adjustable forks is also available.

- Min. Distance over forks - 350 mm
- Max. Distance over forks - 800 mm

Counter balanced stacker with interchangeable accessories is also available.



DRUM TILTER



DRUM GRIPPER



BOOM



JIB CRANE

ALL MODELS ARE AVAILABLE IN HAND OPERATED TYPE, ELECTRICALLY BATTERY OPERATED TYPE, ELECTRICALLY 440V AC POWER OPERATED TYPE & FLAME PROOF TYPE.

MODEL	STO515 CB	STO525 CB	STO530 CB
Lifting capacity (kg)	500	500	500
Max. fork height H1 (mm)	1500	2500	3000

ALL OTHER SPECIFICATIONS SIMILAR TO REGULAR STACKER.