

HYDRAULIC SCISSOR LIFTS

Capacity : 500 to 5000 kg.



STATIONARY TYPE

Capacity : 500 to 5000 kg.



TECHNICAL SPECIFICATIONS

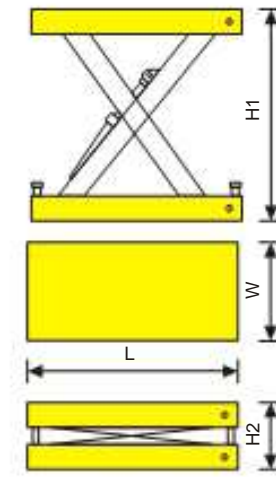

SCISSOR LIFTS MOBILE ON WHEELS

Capacity : 500 & 1000 kg.

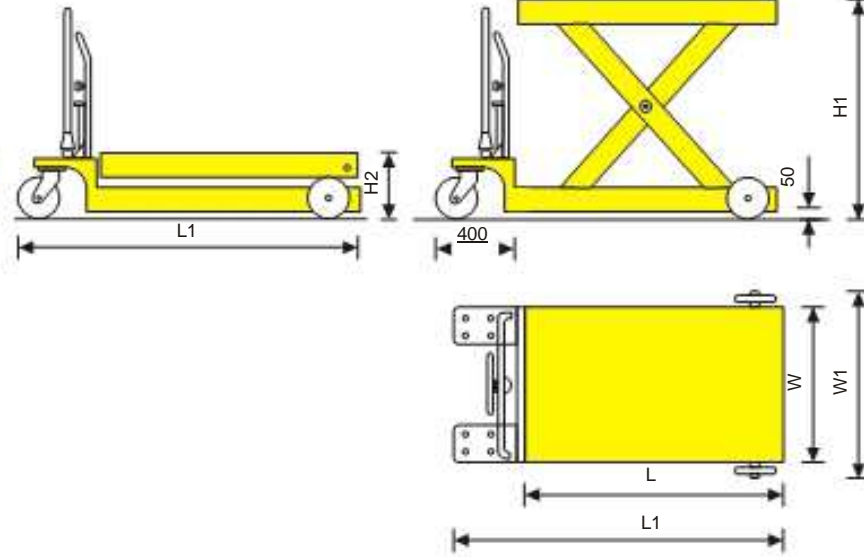

- SS Stands for single scissor, stationery type.
- In case of single scissor, stationery type, Pump or Power Pack is connected to scissor lift by flexible hose & power pack, size @ 400 x 400 is kept near scissor lift at any convenient place.
- In case of single scissor, mobile type, please mention SM in case of SS
- Minimum and Maximum height in case of mobile type scissor increases by 50 mm for wheel ground clearance.
- Overall size in case of mobile type scissor increases by L + 400 mm & W + 200 mm for accommodation of pump unit and wheels.

MODEL	TABLE SIZE L x W (MM)	LOAD CAPACITY (KG)	TABLE HEIGHT MIN. / MAX. (MM)		OVERALL LIFT MM	SIZE L1 x W1 (MM)
SC 0508 SS	1000 x 600	500	300	800	500	1000 x 600
SC 0510 SS	1250 x 700	500	300	1000	700	1250 x 700
SC 0512 SS	1500 x 800	500	300	1200	900	1500 x 800
SC 1009 SS	1000 x 600	1000	400	900	500	1000 x 600
SC 1011 SS	1250 x 700	1000	400	1100	700	1250 x 700
SC1013 SS	1500 x 800	1000	400	1300	900	1500 x 800
SC 1015 SS	2000 x 1200	1000	400	1500	1100	2000 x 1200
SC 1017 SS	2500 x 1500	1000	400	1750	1350	2500 x 1500
SC 1019 SS	3000 x 1800	1000	400	1950	1550	3000 x 1800

DOUBLE SCISSOR LIFT



STATIONARY TYPE

Capacity : 500 & 1000 kg.



TECHNICAL SPECIFICATIONS

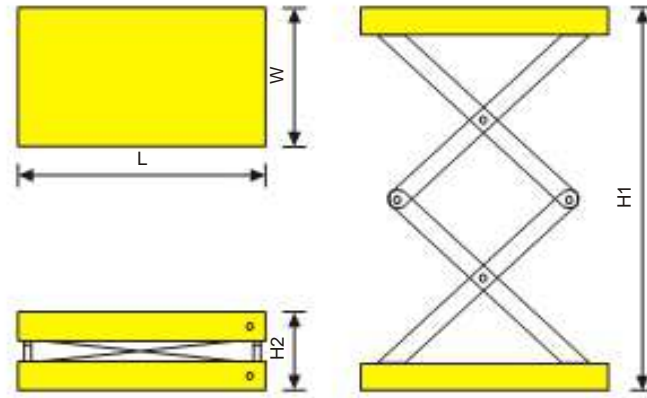

SCISSOR LIFT MOBILE ON WHEELS

Capacity : 500 & 1000 kg.



TECHNICAL SPECIFICATIONS

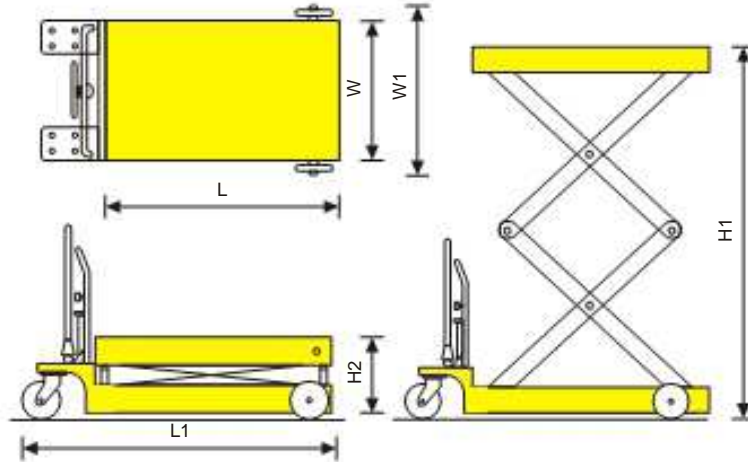

- DS Stands for double scissor, stationery type.
- In case of double scissor, stationery type, Pump / Power Pack is connected to scissor lift by a flexible hose & power pack, size @ 400 x 400 is kept near scissor lift at any convenient place.
- In case of double scissor, mobile type, please mention DM in case of DS.
- Minimum and Maximum height in case of mobile type scissor increases by 50 mm for wheel ground clearance.
- Overall size in case of mobile type scissor increases by L + 400 mm & W + 200 mm for accommodation of pump unit and wheels.

SCISSOR LIFTS ARE AVAILABLE IN HAND OPERATED, BATTERY OPERATED, ELECTRICALLY AC OPERATED & FLAME PROOF TYPE

MODEL	TABLE SIZE L X W (MM)	LOAD CAPACITY (KG)	TABLE HEIGHT MIN. / MAX. (MM)		OVERALL LIFT MM	SIZE L1 x W1 (MM)
SC 0513 DS	1000 x 600	500	400	1300	900	1000 x 600
SC 0515 DS	1250 x 700	500	400	1500	1100	1250 x 700
SC 0517 DS	1500 x 800	500	400	1700	1300	1500 x 800
SC1013 DS	1000 x 600	1000	400	1300	900	1000 x 600
SC 1015 DS	1250 x 700	1000	400	1500	1100	1250 x 700
SC 1017 DS	1500 x 800	1000	400	1700	1300	1500 x 800
SC 1022 DS	2000 x 1200	1000	400	2200	1800	2000 x 1200

CUSTOM BUILT SCISSOR LIFTS



- Single Scissor Lift
- Platform - 3 mtr. x 3 mtr.
- Capacity - 5000 Kg.
- Lift - 1.8 mtr.



- Single Scissor Lift
- Platform - 5 mtr. x 3 mtr.
- Capacity - 5000 Kg.
- Lift - 2.0 mtr.

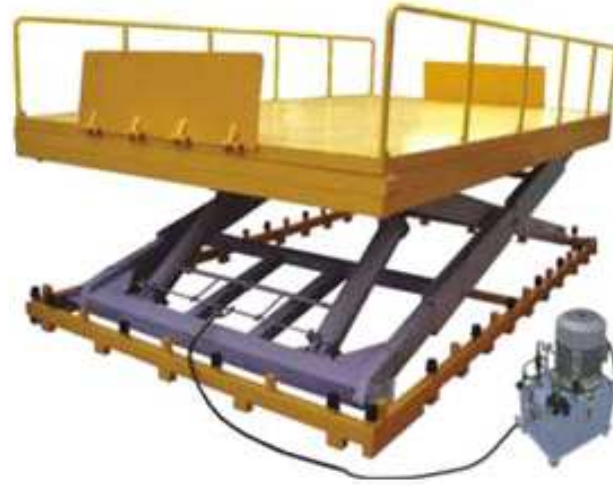

- Single Scissor Lift
- Platform - 3.5 mtr. x 2 mtr.
- Capacity - 3000 Kg.
- Lift - 1.6 mtr.

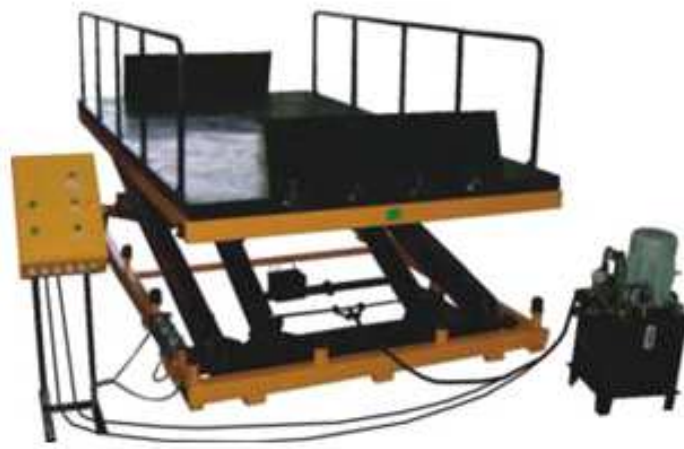

- Triple Scissor Lift
- Platform - 3 mtr. x 2 mtr.
- Capacity - 1000 Kg.
- Lift - 5 mtr.



- Single Scissor Lift
- Platform - 1.8 mtr. x 1 mtr.
- Capacity - 4000 Kg.
- Lift - 1 mtr.



Single Scissor Lift Mobile on Wheels

- Platform - 1250 x 800
- Capacity - 1000 Kg.
- Lift - 600 mm with roller conveyor table at top



CUSTOM BUILT SCISSOR LIFTS



- Single Scissor Lift
- Table - 3000 x 1800 mm
 - Capacity - 2000 Kg.
 - Lift - 1800 mm.
- Provided with drawers for tooling.



Scissor lift kept in concrete constructed pit. Scissor lift top flushed to shop floor for easy loading and unloading.



- Hydraulic Scissor Lift
- Table - 750 x 1200 mm
 - Capacity - 2000 Kg.
 - Lift - 600 mm
- Provided with high pressure pump mounting fixture for testing.



- Double Scissor Lift
- Mobile on Track @ 8 mtr. Long with flanged wheels.
 - Table - 3000 x 2000 mm.
 - Capacity - 500 Kg.
 - Lift - 3500 mm.



