

HYDRAULIC DRUM LIFTER & TILTER

Capacity : 300 kg. Lift : 1500, 2500 & 3000 mm

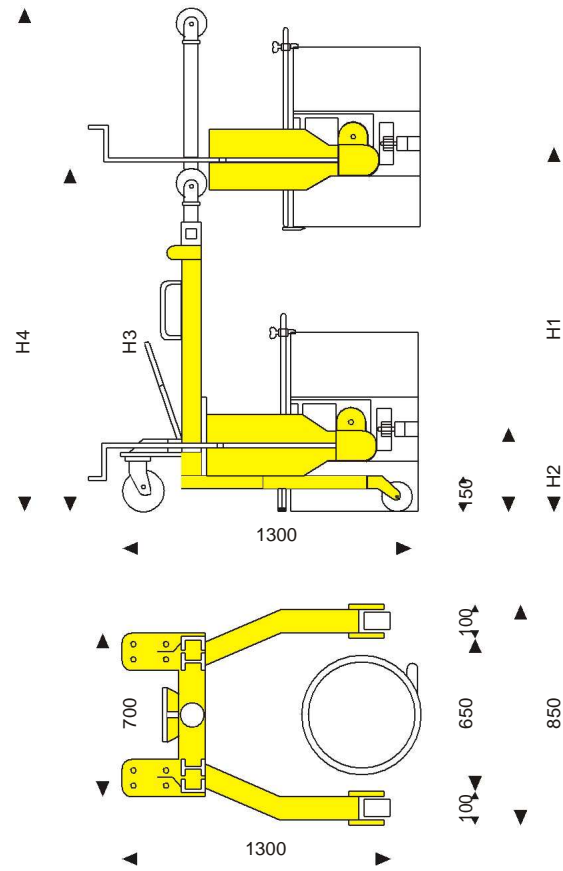

TECHNICAL SPECIFICATIONS



- Overall Size - L 1300 x W 850 mm
- Drum Tilting Angle - 360°
- Front Wheels - Dia 150 x 50 mm - 2 Nos.
- Steering Wheels - Dia 200 x 50 mm - 2 Nos.

IMPORTANT INFORMATION

- Single man operated equipment for vertical lifting, horizontal transportation & 360° rotation of drum.
- Tilting is with worm & worm gear, providing positive self locking at every position of tilt.
- Long hand lever for tilting provides effortless rotation of fully loaded drum without operator's fatigue.
- The chances of accidents due to improper handling of drums are totally avoided.
- The damages & wastage of contents are totally avoided.
- Scientifically designed with in built high quality & safety.

| MODEL | DT0315 | DT0325 | DT0330 |
|-----------------------------|--------|--------|--------|
| Lifting capacity (kg) | 300 | 300 | 300 |
| Max. drum height H1 (mm) | 1500 | 2500 | 3000 |
| Min. drum height H2 (mm) | 400 | 400 | 400 |
| Load centre | 600 | 600 | 600 |
| Lift per stroke (mm) | 20 | 20 | 20 |
| Min. turning radius (mm) | 1600 | 1600 | 1600 |
| Min. overall height H3 (mm) | 1700 | 2200 | 2500 |
| Max. overall height H4 (mm) | 2400 | 3400 | 4000 |

